

# DS14C535

## +5V Supply EIA/TIA-232 3 x 5 Driver/Receiver

### General Description

The DS14C535 is three driver, five receiver which conforms to EIA/TIA-232-E and CCITT (ITU-T) V.28 standard specifications. This device employs an internal DC-DC converter to generate the necessary output levels from a +5V power supply. A SHUTDOWN (SD) mode reduces the supply current to 10  $\mu$ A maximum. In the SD mode, one receiver is active, allowing ring indicator (RI) to be monitored. PC Board space consumption is minimized by the availability of Shrink Small Outline Packaging (SSOP).

The DS14C535 provides a one-chip solution for the common 9-pin serial RS-232 interface between data terminal and data circuit-terminating equipment.

This device allows an easy migration path to the 3.3V DS14C335. The packages are the same. The N/C pins on the DS14C535 are not physically connected to the chip. Board layout for the DS14C335 will accommodate both devices.

This device's low power requirement and small footprint makes it an ideal choice for Laptop and Notebook applications.

### Features

- Pin compatible with DS14C335
- Conforms to EIA/TIA-232-E and CCITT (ITU-T) V.28 specifications
- Failsafe receiver outputs high when inputs open
- Operates with single +5V power supply
- Low power requirement— $I_{CC}$  12 mA maximum
- SHUTDOWN mode— $I_{CX}$  10  $\mu$ A maximum
- One Receiver (R5) active during SHUTDOWN
- Operates up to 128 kbps—Lap-Link® Compatible
- 4V/ $\mu$ s minimum Slew Rate guaranteed
- ESD rating of 3 kV on all pins (H, B, M)
- Available in 28-lead SSOP EIAJ Type II package
- Only four 0.1  $\mu$ F capacitors required for the DC-DC converter

### Connection Diagram

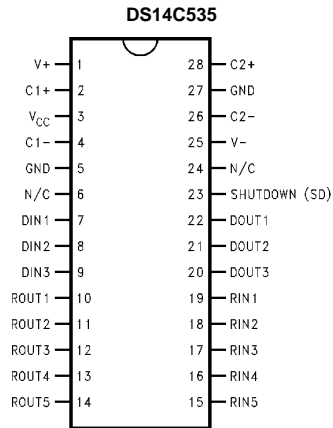

DS011910-1

Order Number DS14C535MSA or DS14C535TMSA  
See NS Package Number MSA28

### Functional Diagram

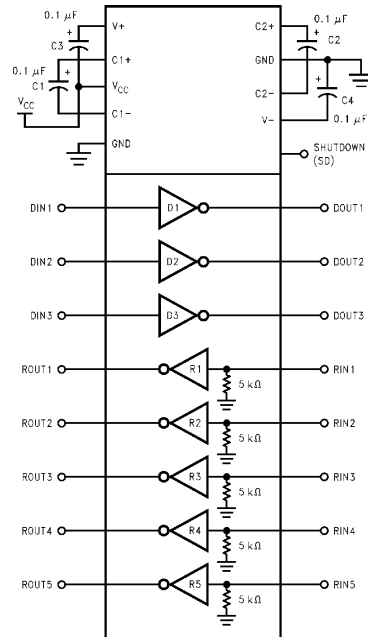

DS011910-2

## Absolute Maximum Ratings (Note 1)

If Military/Aerospace specified devices are required, please contact the National Semiconductor Sales Office/Distributors for availability and specifications.

Supply Voltage ( $V_{CC}$ )	-0.3V to +6V
$V^+$ Pin	( $V_{CC} - 0.3V$ ) to +14V
$V^-$ Pin	+0.3V to -14V
Input Voltage ( $D_{IN}$ , SD)	-0.3V to +5.5V
Driver Output Voltage	( $V^+ + 0.3V$ ) to ( $V^- - 0.3V$ )
Receiver Input Voltage	$\pm 25V$
Receiver Output Voltage	- 0.3V to ( $V_{CC} + 0.3V$ )
Junction Temperature	+150°C
Storage Temperature Range	-65°C to +150°C
Lead Temperature (Soldering 4 sec.)	+260°C
Short Circuit Duration ( $D_{OUT}$ )	Continuous
Maximum Package Power Dissipation @ +25°C	

SSOP MSA Package

1286 mW

Derate MSA Package 10.3 mW/°C above +25°C

ESD Rating (HBM, 1.5 k $\Omega$ , 100 pF)

$\geq 3.0$  kV

## Recommended Operating Conditions

	Min	Max	Units
Supply Voltage ( $V_{CC}$ )	4.5	5.5	V
Operating Free Air Temperature ( $T_A$ )			
DS14C535	0	+70	°C

DC-DC Converter Capacitors (C1-C4)

Recommended range of values is 0.1  $\mu$ F to 0.68  $\mu$ F,  $\pm 20\%$ . For more detail refer to application information section of this data sheet.

## Electrical Characteristics (Note 2) (Note 3)

Over recommended operating conditions, SD = 0.8V, unless otherwise specified.

Symbol	Parameter	Conditions	Min	Typ	Max	Units	
<b>DEVICE CHARACTERISTICS</b>							
$V^+$	Positive Power Supply	No Load		+8.5		V	
$V^-$	Negative Power Supply	C1-C4 = 0.1 $\mu$ F		-7.0		V	
$I_{CC}$	Supply Current	No Load			12	mA	
$I_{CX}$	SHUTDOWN Supply Current	$R_L = 3$ k $\Omega$ , SD = $V_{CC}$		1.0	10	$\mu$ A	
$V_{IH}$	High Level Enable Voltage		SD	2.0		V	
$V_{IL}$	Low Level Enable Voltage			GND	0.8	V	
$I_{IH}$	High Level Enable Current	$2.0V \leq V_{IN} \leq 5.5V$			+2.0	$\mu$ A	
$I_{IL}$	Low Level Enable Current	$GND \leq V_{IN} \leq 0.8V$		-2.0		$\mu$ A	
<b>DRIVER CHARACTERISTICS</b>							
$V_{IH}$	High Level Input Voltage		$D_{IN}$	2.0		V	
$V_{IL}$	Low Level Input Voltage			GND	0.8	V	
$I_{IH}$	High Level Input Current	$2.0V \leq V_{IN} \leq 5.5V$			+1.0	$\mu$ A	
$I_{IL}$	Low Level Input Current	$GND \leq V_{IN} \leq 0.8V$		-1.0		$\mu$ A	
$V_{OH}$	High Level Output Voltage	$R_L = 3$ k $\Omega$		+5.0	8	V	
$V_{OL}$	Low Level Output Voltage				-6.7	-5.0	V
$I_{OS+}$	Output High Short Circuit Current	$V_O = 0V$ , $V_{IN} = 0.8V$ (Note 7)		-40	-20	-8	mA
$I_{OS-}$	Output Low Short Circuit Current	$V_O = 0V$ , $V_{IN} = 2.0V$ (Note 7)		6	15	40	mA
$R_O$	Output Resistance	$-2V \leq V_O \leq +2V$ , $V_{CC} = GND = 0V$		300	1200		$\Omega$
<b>RECEIVER CHARACTERISTICS (Note 4)</b>							
$V_{TH}$	Input High Threshold Voltage	R1-R5, SD = 0.8V (Active Mode)		1.4	2.4	V	
		R5, $2.0V \leq SD \leq 5.5V$ (Shutdown Mode)		2.0	2.8	V	
$V_{TL}$	Input Low Threshold Voltage	R1-R5, SD = 0.8V (Active Mode)	0.8	1.1		V	
		R5, $2.0V \leq SD \leq 5.5V$ (Shutdown Mode)	0.8	1.1		V	
$V_{HY}$	Hysteresis (Note 4)		0.15		1.0	V	
$R_{IN}$	Input Resistance	$V_{IN} = \pm 3V$ to $\pm 15V$	3.0	5.4	7.0	k $\Omega$	

## Electrical Characteristics (Note 2) (Note 3) (Continued)

Over recommended operating conditions, SD = 0.8V, unless otherwise specified.

Symbol	Parameter	Conditions	Min	Typ	Max	Units
<b>RECEIVER CHARACTERISTICS (Note 4)</b>						
$I_{IN}$	Input Current	$V_{IN} = +15V$	2.14		5.0	mA
		$V_{IN} = +3V$	0.43		1.0	mA
		$V_{IN} = -3V$	-1.0		-0.43	mA
		$V_{IN} = -15V$	-5.0		-2.14	mA
$V_{OH}$	High Level Output Voltage	$V_{IN} = -3V, I_{OH} = -2.0 \text{ mA}$	3.8			V
		$V_{IN} = -3V, I_{OH} = -20 \mu\text{A}$	4.0			V
$V_{OL}$	Low Level Output Voltage	$V_{IN} = +3V, I_{OL} = +2.0 \text{ mA}$		0.23	0.4	V

## Switching Characteristics (Note 4)

Over recommended operating conditions, SD = 0.8V, unless otherwise specified.

Symbol	Parameter	Conditions	Min	Typ	Max	Units
<b>DRIVER CHARACTERISTICS</b>						
$t_{PLH}$	Propagation Delay LOW to HIGH	$R_L = 3 \text{ k}\Omega$ $C_L = 50 \text{ pF}$ (Figures 1, 2)	0.1	0.6	1.0	$\mu\text{s}$
$t_{PHL}$	Propagation Delay HIGH to LOW		0.1	0.6	1.0	$\mu\text{s}$
$t_{SK}$	Skew $ t_{PLH} - t_{PHL} $		0	0.2	$\mu\text{s}$	
SR1	Output Slew Rate	$R_L = 3 \text{ k}\Omega$ to $7 \text{ k}\Omega, C_L = 50 \text{ pF}$ (Figure 2)	4	13	30	V/ $\mu\text{s}$
SR2	Output Slew Rate	$R_L = 3 \text{ k}\Omega, C_L = 2500 \text{ pF}$ (Figure 2)	4	10	30	V/ $\mu\text{s}$
$t_{PLS}$	Propagation Delay LOW to SD	(Figures 5, 6)		0.48		ms
$t_{PSL}$	Propagation Delay SD to LOW	$R_L = 3 \text{ k}\Omega$		1.88		ms
$t_{PHS}$	Propagation Delay HIGH to SD	$C_L = 50 \text{ pF}$		0.62		ms
$t_{PSH}$	Propagation Delay SD to HIGH			1.03		ms
<b>RECEIVER CHARACTERISTICS</b>						
$t_{PLH}$	Propagation Delay LOW to HIGH	$C_L = 50 \text{ pF}$ (Figures 3, 4)	0.1	0.4	1.0	$\mu\text{s}$
$t_{PHL}$	Propagation Delay HIGH to LOW		0.1	0.6	1.0	$\mu\text{s}$
$t_{SK}$	Skew $ t_{PLH} - t_{PHL} $		0.1	0.5	$\mu\text{s}$	
$t_{PLS}$	Propagation Delay LOW to SD	(Figures 7, 8)		0.13		$\mu\text{s}$
$t_{PSL}$	Propagation Delay SD to LOW	$R_L = 1 \text{ k}\Omega$		1.0		$\mu\text{s}$
$t_{PHS}$	Propagation Delay HIGH to SD	$C_L = 50 \text{ pF}$		0.19		$\mu\text{s}$
$t_{PSH}$	Propagation Delay SD to HIGH	R1–R4 Only		0.58		$\mu\text{s}$

**Note 1:** "Absolute Maximum Ratings" are those values beyond which the safety of the device cannot be guaranteed. They are not meant to imply that the devices should be operated at these limits. The tables of "Electrical Characteristics" specify conditions for device operation.

**Note 2:** Typical values are given for  $V_{CC} = 5V$  and  $T_A = +25^\circ\text{C}$ .

**Note 3:** Current into device pins is defined as positive. Current out of device pins is defined as negative. All voltages are referenced to ground unless otherwise specified. For voltage logic levels, the more positive value is designated as maximum. For example, if  $-5V$  is a maximum, the typical value ( $-6.7V$ ) is more negative.

**Note 4:** Receiver characteristics are guaranteed for SD = 0.8V. When SD = 2.0V, receiver five (R5) is active and meets receiver parameters in SHUTDOWN (SD) mode, unless otherwise specified.

**Note 5:** Generator characteristics for driver input:  $f = 64 \text{ kHz}$  (128 kbits/sec),  $t_r = t_f < 10 \text{ ns}$ ,  $V_{IH} = 3V$ ,  $V_{IL} = 0V$ , duty cycle = 50%.

**Note 6:** Generator characteristics for receiver input:  $f = 64 \text{ kHz}$  (128 kbits/sec),  $t_r = t_f < 10 \text{ ns}$ ,  $V_{IH} = 3V$ ,  $V_{IL} = -3V$ , duty cycle = 50%.

**Note 7:** Only one driver output shorted at a time.

## Parameter Measurement Information

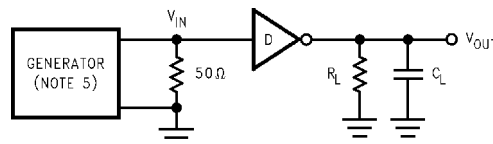

FIGURE 1. Driver Propagation Delay and Slew Rate Test Circuit

DS011910-3

## Parameter Measurement Information (Continued)

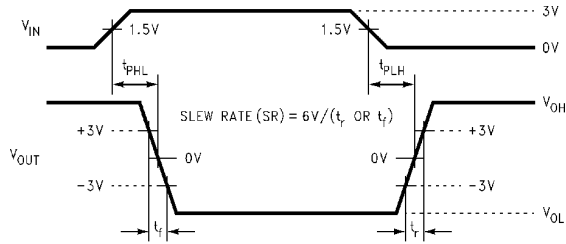

FIGURE 2. Driver Propagation Delay and Slew Rate Timing

DS011910-4

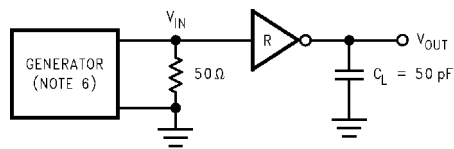

FIGURE 3. Receiver Propagation Delay Test Circuit

DS011910-5

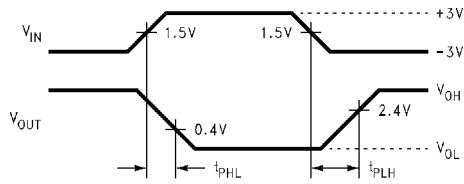

FIGURE 4. Receiver Propagation Delay Timing

DS011910-6

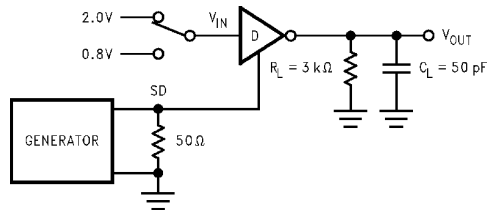

FIGURE 5. Driver SHUTDOWN (SD) Delay Test Circuit

DS011910-7

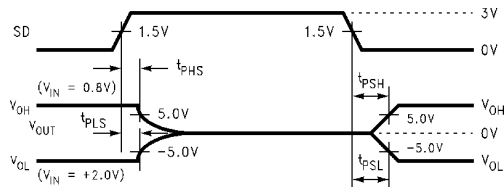
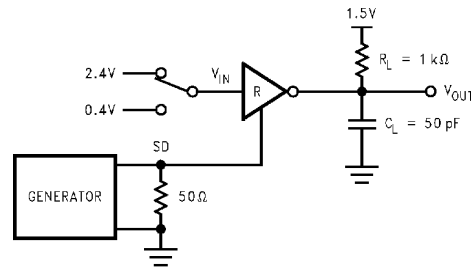

FIGURE 6. Driver SHUTDOWN (SD) Delay Timing

DS011910-8

## Parameter Measurement Information (Continued)



DS011910-9

FIGURE 7. Receiver SHUTDOWN (SD) Delay Test Circuit

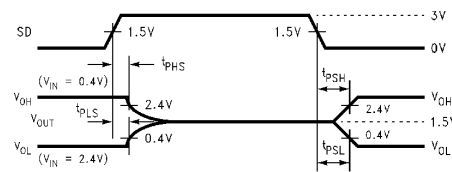

DS011910-10

FIGURE 8. Receiver SHUTDOWN (SD) Delay Timing

## Pin Descriptions

**V<sub>CC</sub> (Pin 3).** Power supply pin for the device, +5V ( $\pm 0.5$ V).

**V<sub>+</sub> (Pin 1).** Positive supply for EIA/TIA-232-E drivers. Recommended external capacitor—0.1  $\mu$ F (16V). This supply is not intended to be loaded externally.

**V<sub>-</sub> (Pin 25).** Negative supply for EIA/TIA-232-E drivers. Recommended external capacitor—0.1  $\mu$ F (16V). This supply is not intended to be loaded externally.

**C1+, C1- (Pins 2, 4).** External capacitor connection pins.

**C2+, C2- (Pins 28, 26).** External capacitor connection pins.

**SHUTDOWN (SD) (Pin 23).** A High on the SHUTDOWN pin will lower the total  $I_{CC}$  current to less than 10  $\mu$ A, providing a low power state. In this mode receiver R5 remains active. The SD pin should be driven or tied low (GND) to disable the shutdown mode.

**D<sub>IN</sub> 1–3 (Pins 7, 8, 9).** Driver input pins.

**D<sub>OUT</sub> 1–3 (Pins 22, 21, 20).** Driver output pins conform to EIA/TIA-232 -E levels.

**R<sub>IN</sub> 1–5 (Pins 19, 18, 17, 16, 15).** Receiver input pins accept EIA/TIA-232-E input voltages ( $\pm 25$ V). Receivers guarantees hysteresis of TBD mV. Unused receiver input pins may be left open. Internal input resistor (5 k $\Omega$ ) pulls input LOW, providing a failsafe HIGH output.

**R<sub>OUT</sub> 1–5 (Pins 10, 11, 12, 13, 14).** Receiver output pins.

**GND (Pins 5, 27).** Ground Pins. Both pins must be connected to external ground. These pins are not connected together on the chip.

## Application Information

In a typical Data Terminal Equipment (DTE) to Data Circuit-Terminating Equipment (DCE) 9-pin de-facto interface implementation, 2 data lines and 6 control lines are required. The data lines are TXD and RXD and the control lines are RTS, DTR, DSR, DCD, CTS and RI. The DS14C535 is a 3 x 5 Driver/Receiver and offers a single chip solution for the DTE interface as shown in Figure 9.

Ring Indicator (RI) is used to inform the DTE that an incoming call is coming from a remote DCE. When the DS14C535 is in SHUTDOWN (SD) mode, receiver five (R5) remains active and monitors RI circuit. This active receiver (R5) alerts the DTE to switch the DS14C535 from SHUTDOWN to active mode.

To achieve minimum power consumption, the DS14C535 can be in SHUTDOWN mode and only activated when communications are needed.

**Application Information** (Continued)

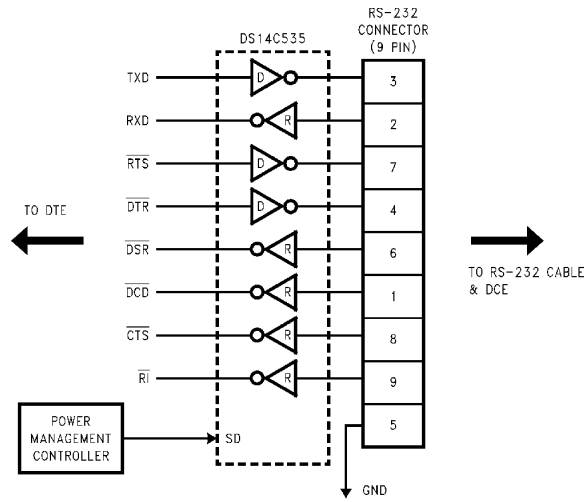

**FIGURE 9. Typical DTE Application**

DS011910-11

## Application Information (Continued)

### Capacitors:

Capacitors can be ceramic or tantalum. Standard surface mount in the range of 0.1  $\mu\text{F}$  to 0.68  $\mu\text{F}$  are readily available from several manufacturers. A minimum 20V rating is recommended. Contact manufacturers for specific detail on surface mounting and dielectrics. A partial list of manufacturers include:

Manufacturer	Phone Number
KEMET	803-963-6300
AVX	803-448-9411
MURATA-ERIE	800-831-9172

Book  
Extract  
End

**Physical Dimensions** inches (millimeters)

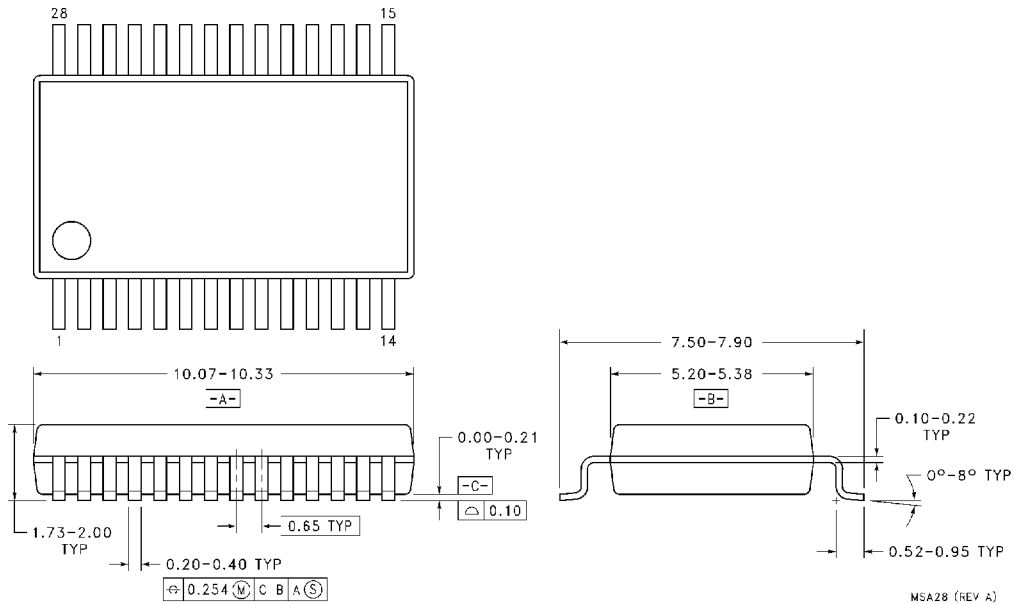

Order Number DS14C535MSA or DS14C535TMSA  
NS Package Number MSA28

**LIFE SUPPORT POLICY**

NATIONAL'S PRODUCTS ARE NOT AUTHORIZED FOR USE AS CRITICAL COMPONENTS IN LIFE SUPPORT DEVICES OR SYSTEMS WITHOUT THE EXPRESS WRITTEN APPROVAL OF THE PRESIDENT OF NATIONAL SEMICONDUCTOR CORPORATION. As used herein:

1. Life support devices or systems are devices or systems which, (a) are intended for surgical implant into the body, or (b) support or sustain life, and whose failure to perform when properly used in accordance with instructions for use provided in the labeling, can be reasonably expected to result in a significant injury to the user.
2. A critical component in any component of a life support device or system whose failure to perform can be reasonably expected to cause the failure of the life support device or system, or to affect its safety or effectiveness.

 <p><b>National Semiconductor Corporation</b> 1111 West Bardin Road Arlington, TX 76017 Tel: 1(800) 272-9959 Fax: 1(800) 737-7018  www.national.com</p>	<p><b>National Semiconductor Europe</b> Fax: (+49) 0-180-530 85 86 Email: cnjwge@tevm2.nsc.com Deutsch Tel: (+49) 0-180-530 85 85 English Tel: (+49) 0-180-532 78 32 Français Tel: (+49) 0-180-532 93 58 Italiano Tel: (+49) 0-180-534 16 80</p>	<p><b>National Semiconductor Hong Kong Ltd.</b> 13th Floor, Straight Block, Ocean Centre, 5 Canton Rd. Tsimshatsui, Kowloon Hong Kong Tel: (852) 2737-1600 Fax: (852) 2736-9960</p>	<p><b>National Semiconductor Japan Ltd.</b> Tel: 81-043-299-2308 Fax: 81-043-299-2408</p>
--	--	---	---

National does not assume any responsibility for use of any circuitry described, no circuit patent licenses are implied and National reserves the right at any time without notice to change said circuitry and specifications.